

# SECTION 7 DETAILS OF BRACED COMPONENTS

## SEISMIC WIRE ROPE/CABLE™ ASSEMBLIES FOR BRACES

**NOTES:**

1. Install cable assemblies with a minimum angle of the cable from the vertical plane per Section 3 & 4 Selection Tables.
2. Anchorage of the cable assemblies to the structure to be per Section 3 & 4 Selection Tables.
3. Tighten cables only to remove excessive slack.
4. After tightening cables to remove excessive slack on vibration isolated components, loosen each cable 1/4" at oval sleeves before crimping.

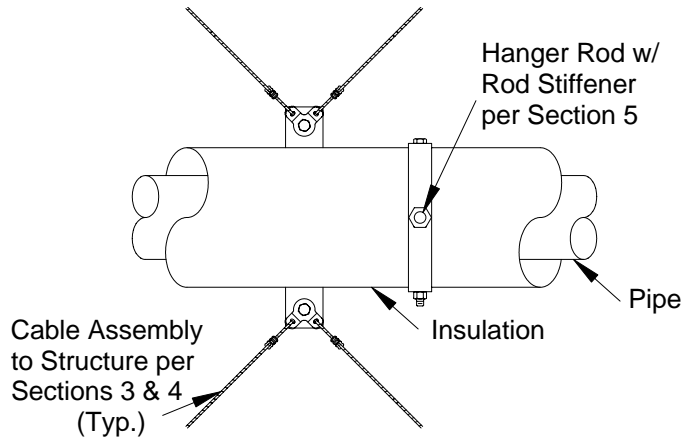

**PLAN VIEW**

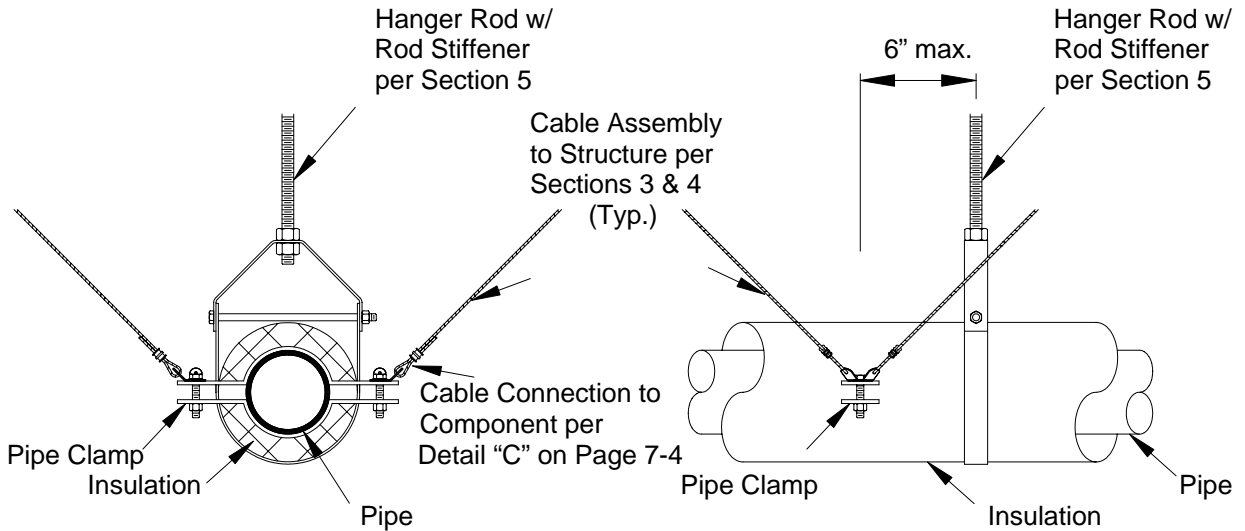

**END VIEW**

**SIDE VIEW**

(only the two cables in foreground shown for clarity)

## 4-WAY SWAY BRACE DETAIL FOR INSULATED PIPE & CONDUIT

**APPROVED**  
**Fixed Equipment Anchorage**  
Office of Statewide Health Planning and Development

**OPA-0619      05/01/04**

\*\*\*\* Valid for 3 Years Maximum \*\*\*\*



*Anthony Pike*  
Anthony Pike      916-324-9078



**LOOS & CO.**

CABLEWARE® DIVISION  
Seismic Wire Rope/Cable™ Bracing  
[www.earthquakebrace.com](http://www.earthquakebrace.com)

901 INDUSTRIAL BLVD.  
NAPLES, FL 34104  
PHONE : 1-800-321-5667  
FAX : 1-239-643-4558



© Loos & Co., Inc. 2004

*Anwar Yusuf*  
Anwar Yusuf  
Structural Engineer  
California SE No. S-3625

Page  
**7-16**  
5/1/04