

SECTION 7 DETAILS OF BRACED COMPONENTS

SEISMIC WIRE ROPE/CABLE™ ASSEMBLIES FOR BRACES

Cable Assembly to Structure per Sections 3 & 4 (Typ.)

Cable Connection to Component per Detail "D" on Page 7-4

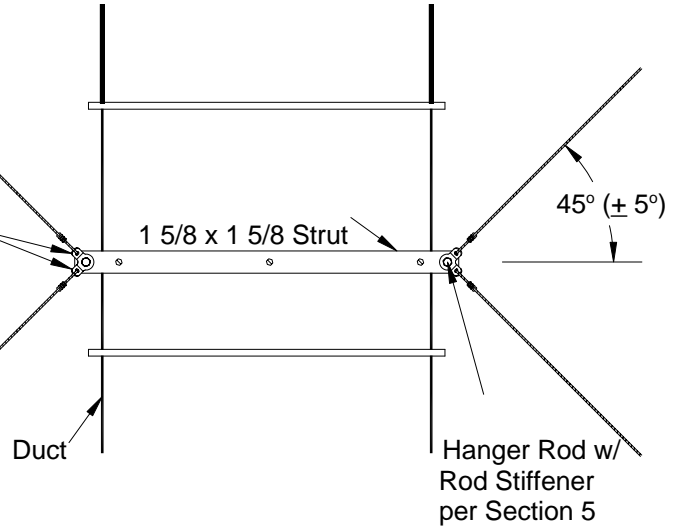

PLAN VIEW

NOTES:

1. Install cable assemblies with a minimum angle of the cable from the vertical plane per Section 3 & 4 Selection Tables.
2. Anchorage of the cable assemblies to the structure to be per Section 3 & 4 Selection Tables.
3. Tighten cables only to remove excessive slack.
4. After tightening cables to remove excessive slack on vibration isolated components, loosen each cable 1/4" at oval sleeves before crimping.

Minimum Brace Angle per Tables in Section 3

Hanger Rod w/ Rod Stiffener per Section 5

Cable Assembly to Structure per Sections 3 & 4 (Typ.)

No. 10 Self-Tapping Sheet Metal Screws (max. 12" o.c.)

Rectangular Duct (shown)
Flat Oval Duct (in broken line)

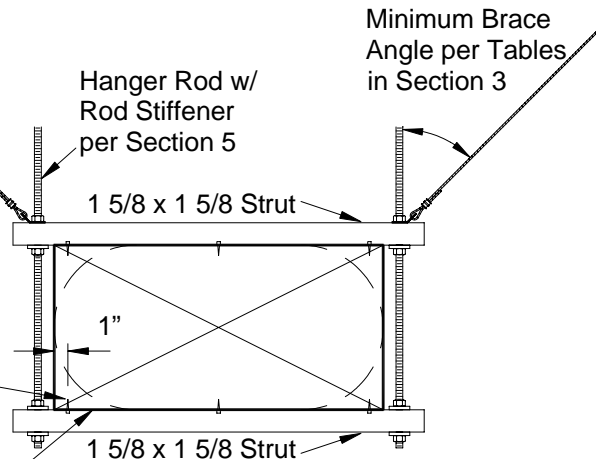

END VIEW

(only the two cables in foreground shown for clarity)

4-WAY SWAY BRACE DETAIL FOR RECTANGULAR & FLAT OVAL DUCTS (Braced at Top of Duct)

APPROVED
Fixed Equipment Anchorage
Office of Statewide Health Planning and Development

OPA-0619 05/01/04

**** Valid for 3 Years Maximum ****



Anthony P. Pile
Anthony Pile 916-324-9078



901 INDUSTRIAL BLVD.
NAPLES, FL 34104
PHONE : 1-800-321-5667
FAX : 1-239-643-4558

CABLEWARE® DIVISION
Seismic Wire Rope/Cable™ Bracing
www.earthquakebrace.com



© Loos & Co., Inc. 2004

Anwar Yusuf
Anwar Yusuf
Structural Engineer
California SE No. S-3625

Page
7-17
5/1/04